



ADVANCED  
ALUMINIUM  
SOLUTIONS



ENERGY SOLUTIONS  
Architectural Systems



## QUALITY LIVING

Modern urbanization sets people inside buildings for more than 90% of their total daily time (York University, York.ac.uk). Sleeping, eating, working, entertainment and the rest of our actions take place within the walls.

Since 1970, when contemporary urban model appeared through the mass construction of block of flats, new diseases developed due to the environment inside the new buildings (SBS: Sick Buildings Syndrome).

That is why, designing and construction should fulfill the highest expectations in terms of lighting, ventilation, warmth /coolness and soundproof.

Windows play a leading part to all the above, as they affect many of those factors that set a building "user friendly".

## ALUMINIUM: A FRIENDLY METAL

Aluminium allows rooms to "breathe" and at the same time, by using contemporary technology methods, offers **exceptional Thermal Insulation**.

Aluminium belongs to light metals, with high strength, suitable for large constructions that allow the inflow of natural light.

Aluminium is durable, adding timeless value to buildings needing the least of maintenance.

It is 100% recyclable, using only 5% of the total primary energy needed, to get recycled.

Aluminium windows offer numerous advantages to the building users and create quality environments.

## SUSTAINABLE LIVING



## OUR BUSINESS ... OUR PASSION

ELVIAL aims to be part of the solution for contemporary socio – environmental issues, therefore **we design imaginatively** and **we produce responsibly**. We create novelties that **answer to every need of yours**.

### I NEED SECURITY:

In the year 2004 ELVIAL responded to the fundamental issue of security, inventing the **international, patented innovation ELVIAL MULTILOCK**. **ELVIAL MULTILOCK** systems achieve **exceptional anti-burglar performance**, having up to **21 steel locking points**, around the window, ensuring security even to tilt position.

### I NEED THERMAL INSULATION:

In the year 2014 with the international innovative **Technology ELVIAL I<sup>2</sup>**, we offer premium thermal insulation, applied to a full range of products, ideally combined with all the advantages that ELVIAL aluminium products offer: **security, soundproof, excellent functionality & durability for a lifetime, high aesthetics - colors - different color inside & outside**.

### I NEED GARANTEED QUALITY & PROMISING CUSTOMER CARE:

We design, we produce and distribute **ELVIAL** systems **exclusively** in our high - end, robotic industrial complex. For the construction and the placement of your aluminium windows we cooperate only with **distinguished partners** that dispose the highest quality and technology standards.

We constantly invest in **cutting -edge Technology** and **robotic Logistic Systems**, while we believe that **our most precious resource is our People**. We produce according to the strictest Standard for Aluminium Extruded Profiles **EN15088** (CE marking) and all our processes are managed according to **ISO 9001:2008**.

In that way, we ensure factory quality and excellent customer care.

We respect the environment, producing under the **ISO 14001:2004** and we function according to **OHSAS 18001:2007** ensuring health and safety inside the premises, because we believe that our responsibility does not only concern our premium quality products but also to our every day actions.



INTERNATIONAL INNOVATIVE  
INSULATION TECHNOLOGY

only by ELVIAL

ELVIAL recognizes that during difficult socio - economical periods, a **money -saving technology** fulfills every contemporary architectural need and becomes a true **opportunity** and **passport** for a **sustainable and promising future**.

That is why we develop pioneering solutions, in order to **boost the economy** in combination with environmental protection for future generations.

That is what ELVIAL I<sup>2</sup> Technology stands for.

#### ⊕ FACTORY ASSURANCE

I<sup>2</sup> Technology is **exclusively** implemented in the robotic industrial complex of ELVIAL, without any further, outsource interference.

#### ⊕ APPLICATION RANGE

There is a full range of products available, consisted from the thermal brake MULTILOCK, XCLUSIVE and LIFT & SLIDE series, fulfilling every consumer's need, covering a plethora of design options.

#### ⊕ CONSUMER BENEFITS

For the first time, consumers enjoy the valuable advantages of **security, soundproof, perfect functionality & durability for a lifetime, high aesthetics** with colors and double colors (different color inside & outside) ideally combined with **excellent thermal insulation for direct gain**.

#### TECHNOLOGY ELVIAL I<sup>2</sup>

Additional **Insulation Zone** with **foam filled** thermal brake chamber.

The profile thermal transmittance value (Uf) can be improved up to 38%.

#### INSULATION MATERIAL ELVIAL I<sup>2</sup>

- ▶ With **CERTIFIED** - from the accredited Body CEIS- thermal conductivity value  $\lambda$  0,022 W/mK
- ▶ Has the **optimum density** for perfect thermal insulation
- ▶ Custom made for ELVIAL



THE FOLLOWING PAGES CONCERN ALL OF YOU THAT YOU ARE LOOKING FOR...

↓ Practical upgrade of your project, emphasizing on details.

↓ Ways to get informed about all those topics that are related to contemporary values and trends.

↓ Improvement of your environmental print.

↓ Application of all principles and values related to environment - society - people.

↓ Superiority and added value compared to the competition.

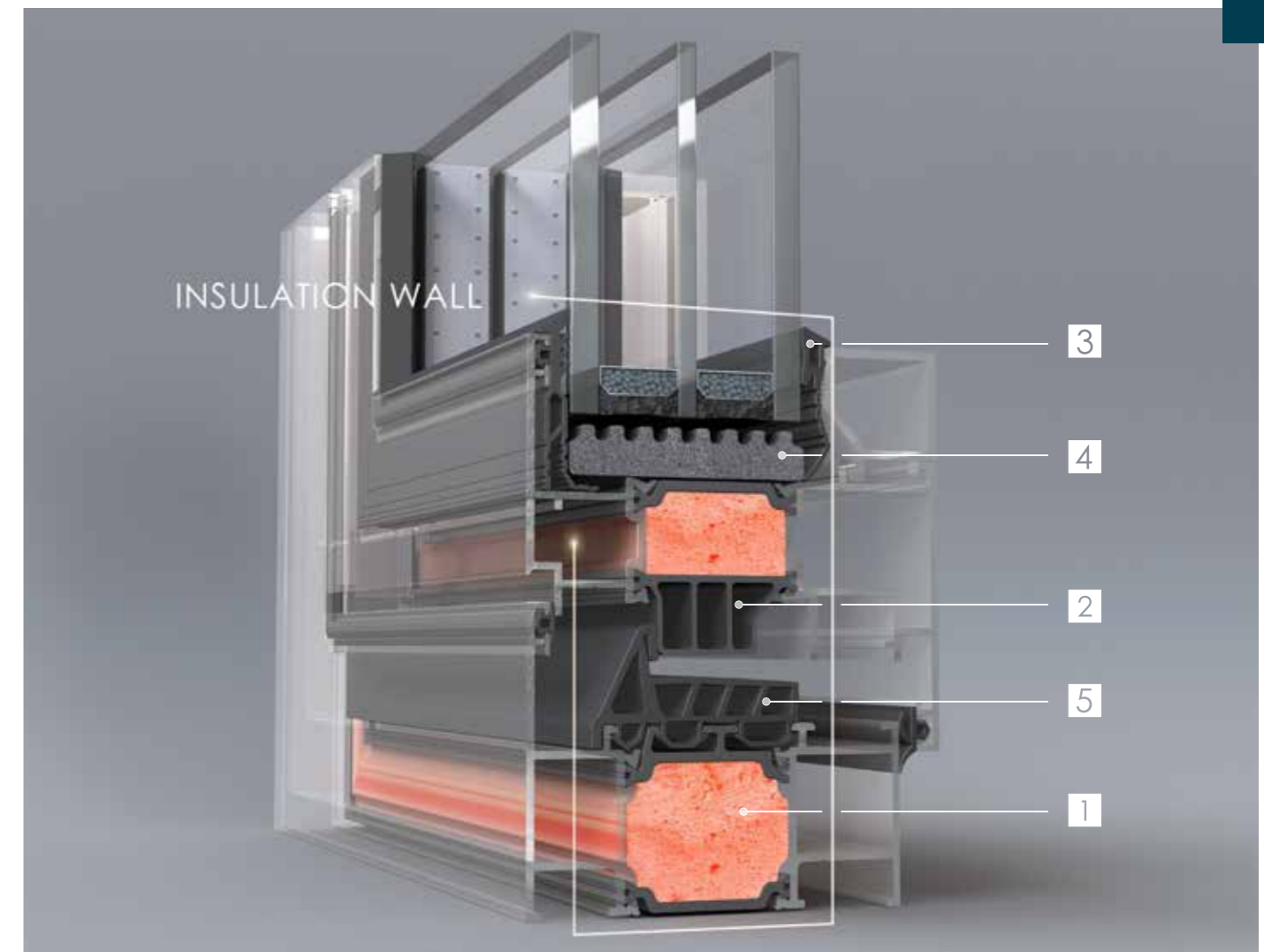

### ELVIAL INSULATION WALL

Optimum insulation of a building, not only creates comfortable living, but also energy saving, that automatically means **economical** and **environmental benefit**.

In ELVIAL, we "build" an insulation wall to the aluminium systems.

The application of the new **Technology ELVIAL I<sup>2</sup> 1**, optimizes the isothermal flow and eliminates the transmission of the heat by radiation. **Polyamide** or **Polythermide bars 2**, that interfere between the inside and the outside part of the profile, are used for the effective insulation of a window. The width and the shape of the bar differentiate the energy performance of the system.

One of the weakest points of construction is the meeting point of the sash and the glazing. Using **perimetrical glazing gaskets with fins 3** as well as **low density polyethylene 4**, this spot gets perfectly insulated. The **cellular central gasket 5** fully covers the polyamide and becomes an additional insulation zone for the window.



## SECURITY

Feeling secure is an irreplaceable value, while protecting our beloveds is a primitive instinct.

According to statistics, 8 out of 10 house burglaries, where caused by breaking the windows.

Creating Safe Environments is our priority, that is why we invented the international patented ELVIAL MULTILOCK systems.

ELVIAL MULTILOCK systems excel to five crucial points and were the first aluminium systems that were **WK2** certified:

- 1 perimetric locking up to 21 points exclusively with:
    - ▶ "mushroom head", steel armour pins (not roller)
    - ▶ special safety **locking plates**, that prevent from unlocking in case of a burglary.
- For lift & slide systems a **special anti lift mechanism** is applied, preventing from lifting and finally removing the sash.



- 2 **Tubular glazing bead** succeeds ultimate resistance against any pressure, attempting to subtract the glass out of the window.
- 3 **Secustik handles** that make more difficult to move the window fitting unlawfully from outside.
- 4 Certified according to DIN EN 356 Class P4A, **security glazing**.
- 5 Window mounting in galvanized steel frame, fixed with steel nails in masonry, or alternatively anchoring in concrete with special screw - anchors without plugs ( type SPAX - RA) or similar.



## ELVIAL ADVANCED SEALING SYSTEM

ELVIAL products offer exceptional water resistance (up to 300Pa) and wind permeability resistance (Class 4 – EN12210).

In opening systems we emphasize to the mullion (joining point of the 2 sashes), choosing **mullion end cups**, specially designed, made of double material (TPV+EPDM) sealing perfectly onto the profile, ensuring excellent water tightness.

We set as a precondition the use of **EPDM gasket corners** for the central and the outer glazing gasket, protecting effectively one of the weakest points of a window construction.

Special drainage channels on the frame and on the sash, that prevent water from flowing to the inner part of the profile.

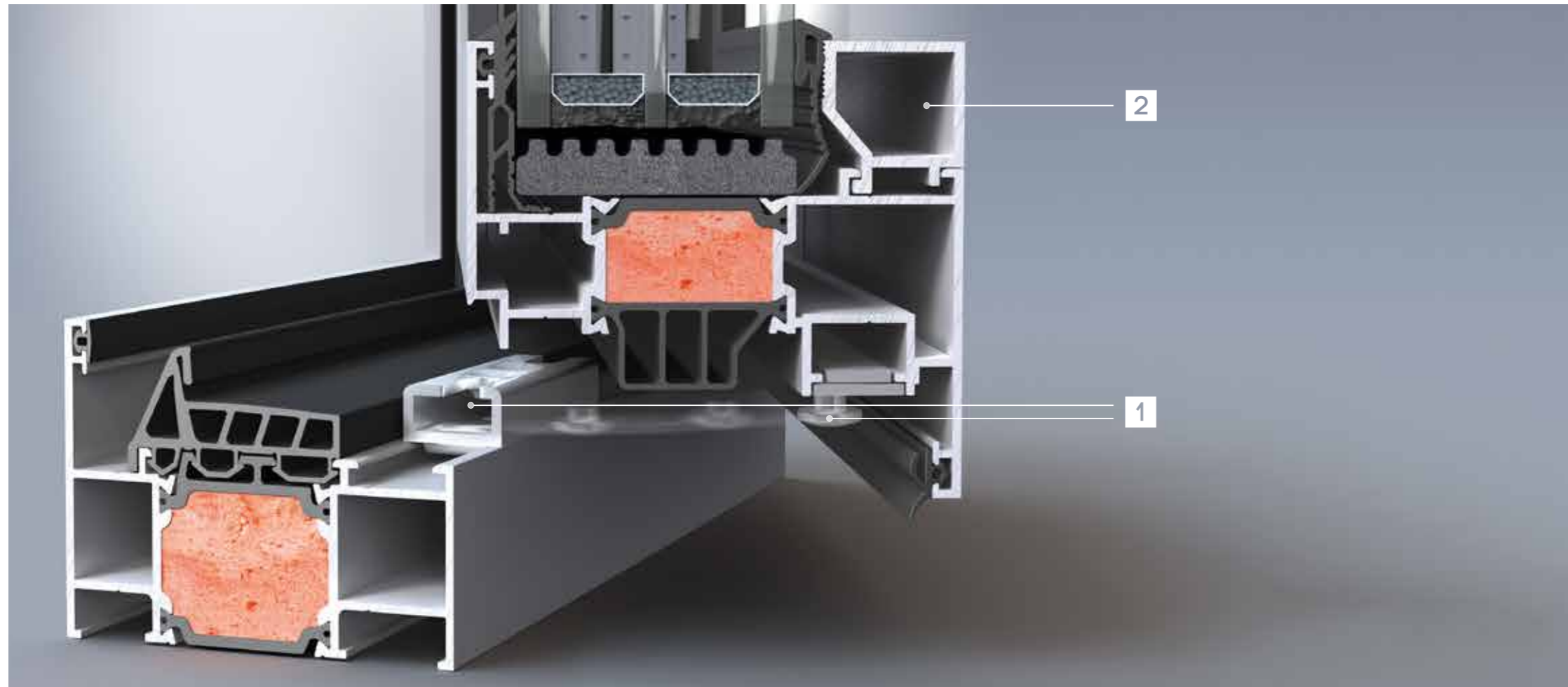

## PERFECT FUNCTIONALITY FOR A LIFE TIME

A quality window requires the least of maintenance and functions perfectly for a lifetime.

The characteristics and the mechanism of a window are the key to its robustness.

In openings, we use **solid corners joints** with specially design recesses to fasten the hinge pins, absorbing the glazing weight and ensuring the long lasting operation of the final product.

In lift & slides we use 2 kind of corner joints:

1. **Crimped** corner joints (use of crimping machine).
2. **Mechanical corner joints**, innovatively designed, **clutching to the aluminium** and not to the polyamide.

We use **alignment corners** made of polyamide material, giving extra rigidity. For systems specially designed for complex and demanding constructions we choose special **alignment corners with channels for glue inflow**, that re-enforce the construction and make a perfect assembly.

We prefer European labeled mechanisms (hinges, locking systems e.t.c.), that fulfill high quality standards.

To heavy duty systems we design profiles with re-enforced thickness for **high values of moment of inertia**.

## HIGH AESTHETICS – COLOR OPTIONS

Superficial processes of profiles are: powder coating and anodizing. Both ways of overcoating, mainly protect the profile from possible erosion and secondly give perfect finish.

We dye all of our products thoroughly, to the vertical powder coating unit using special multitrionic robots. There are 12, chrome free, chemical preparation stages creating a **super durable substrate** that ensures **long lasting final result**. The whole coloring procedure is **QUALICOAT** and **SEASIDE CLASS** certified, because we insist not only to high quality but to **certified quality** also.

We cooperate with **distinguished powder suppliers** world wide, ensuring the best of quality.

We offer **400+ color shades** proving you with numerous options.

Our proposal is double color, different color inside and outside. A high aesthetics suggestion, custom made for you.

Colors can affect the image and the feeling of an environment. Choosing colors is a **pleasant procedure that activates our creativity and upgrades our everyday living**.

Which colors do you chose?



**XPERIENCE**





The New Window Systems ELVIAL **XCLUSIVE 85i<sup>2</sup> / 86i<sup>2</sup>**, are here to offer superior performance in energy efficiency, safety, sound insulation & contemporary design.



**XCLUSIVE 86i<sup>2</sup> Multilock**

# XCLUSIVE 85i<sup>2</sup> / 86i<sup>2</sup>

## FEATURES + BENEFITS

**OUTSTANDING THERMAL INSULATION**  
**U<sub>f</sub>** : 1.1 – 1.6 W/m<sup>2</sup>K  
**U<sub>w</sub>\*** : 1.4 W/m<sup>2</sup>K with double glazing (U<sub>g</sub>: 1.0)  
**U<sub>w</sub>\*** : 1.1 W/m<sup>2</sup>K with triple glazing (U<sub>g</sub>: 0.6)  
**U<sub>w</sub>\*\*** : 0.81 W/m<sup>2</sup>K with triple glazing (U<sub>g</sub>: 0.5)

- Three insulation levels:
- ▶ Optimized **foam-filled insulation zone (ELVIAL I<sup>2</sup> Technology)** that ensures excellent isothermal flow of the window.
  - ▶ **Multi-chamber polyamide bars 34mm** with glass fibers reinforcement 25%, (PA6.6 25 GF), for excellent insulation and extra rigidity.
  - ▶ Specially designed **central gasket with 5 cavities** that covers all the polyamide surface, **glazing gaskets with fins** and **perimetrical insulation** with low density polyethylene, for effective heat transfer minimization.

**SECURITY**  
**WK2** security level, with up to **21** perimetric locking points.

**DURABILITY FOR A LIFETIME**  
**Width** up to **1.600mm** / sash ■ **Height** up to **2.400mm**  
**Weight** up to **130kg** / sash ■ **Glazing** up to **60mm**

- Perfect functionality:
- ▶ **3 Axis polyamide alignment corners** with channels for **glue inflow**, for extra rigidity of the final product.
  - ▶ **Corner Joints** with specially designed **recesses to fasten the hinge pins** absorbing the glazing weight and ensuring long lasting operation of the final product.
  - ▶ Re-enforced profile wall thickness (1.5 – 2.0 mm) with **high values of moment of inertia**, suitable for wide and complex constructions.

- ADVANCED SEALING SYSTEM, CONSISTED OF:**
- ▶ Innovative **Mullion End Cap** made of **TPV + EPDM** to seal perfectly onto the profile, ensuring excellent watertightness.
  - ▶ **EPDM Gasket Corners** for the central gasket and the outer glazing gasket.
  - ▶ **Special drainage channels** on the frame and on the sash, which prevent water from flowing to the inner part of the profile.

**BASIC SYSTEM DEPTH:** 77mm  
**MINIMUM FACE WIDTH F-S:** 109.5mm

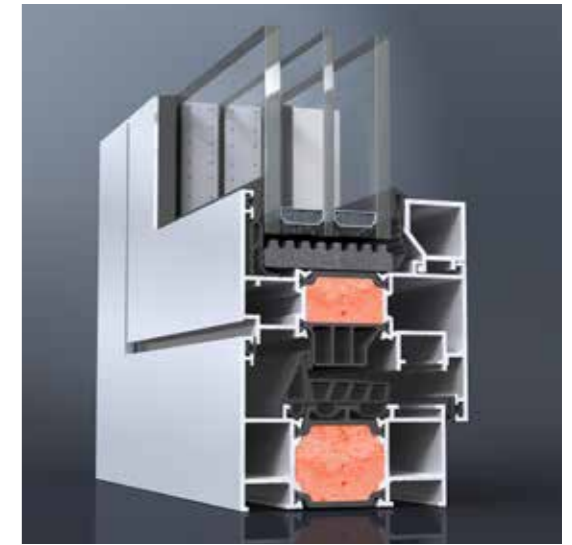

**XCLUSIVE 86i<sup>2</sup> Multilock**

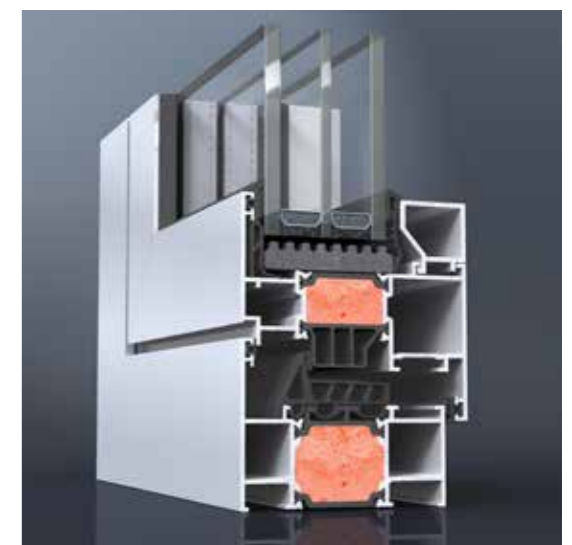

**XCLUSIVE 85i<sup>2</sup> Camera Europea**

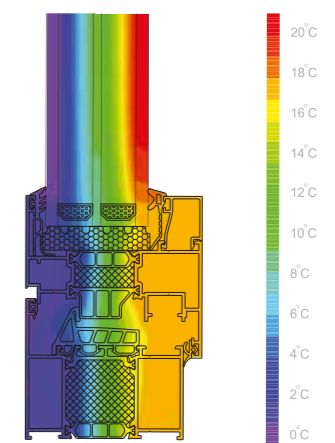

**XCLUSIVE 86i<sup>2</sup> Multilock Isothermal Flow**

\* One sash construction 1.400mm X 1.400mm  
 \*\* One sash construction 1.600mm x 2.400mm





“

We create partnerships

stronger than aluminium

”

